

SEA HOUSE APARTMENTS

601 S Ocean Dr. Fort Pierce FL 34949



FOR SALE | \$3,200,000

**JEREMIAH BARON
& CO**

COMMERCIAL REAL ESTATE

2100 SE Ocean Blvd. Suite 100
Stuart FL, 34996
www.commercialrealestatellc.com

Brian Schwan
772.286.5744 Office
772.215.1167 Mobile
bschwan@commercialrealestatellc.com

PROPERTY OVERVIEW

- Discover a prime investment with this 12-unit multifamily apartments currently grossing \$225,000 annually.
- The unit mix includes two spacious 2-bedroom/2-bathroom units, three comfortable 1-bedroom/1-bathroom units, and seven efficiently designed units.
- The strategic location along the Atlantic coast further adds value to the investment, as it positions the property within a desirable and sought-after destination. The potential for high rental demand, coupled with the picturesque surroundings, ensures not just a sound financial investment but also an opportunity to capitalize on the growing market for vacation rentals.



PRICE	\$3,200,000
TOTAL AREA	5,569 SF (combined)
BUILDING TYPE	Multifamily
ACREAGE	0.46 AC
FRONTAGE	78.75'
TRAFFIC COUNT	7,400 ADT
YEAR BUILT	1950–1952
CONSTRUCTION TYPE	CB Stucco
ZONING	R-4A
LAND USE	HIR
PARCEL ID	2401-502-0020-000-4

NO WARRANTY OR REPRESENTATION, EXPRESS OR IMPLIED, IS MADE AS TO THE ACCURACY OF THE INFORMATION CONTAINED HEREIN, AND THE SAME IS SUBMITTED SUBJECT TO ERRORS, OMISSIONS, CHANGE OF PRICE, RENTAL OR OTHER CONDITIONS, PRIOR SALE, LEASE OR FINANCING, OR WITHDRAWAL WITHOUT NOTICE, AND OF ANY SPECIAL LISTING CONDITIONS IMPOSED BY OUR PRINCIPALS NO WARRANTIES OR REPRESENTATIONS ARE MADE AS TO THE CONDITION OF THE PROPERTY OR ANY HAZARDS CONTAINED THEREIN ARE ANY TO BE IMPLIED.

**JEREMIAH BARON
& CO**
COMMERCIAL REAL ESTATE

2100 SE Ocean Blvd. Suite 100
Stuart FL, 34996
www.commercialrealestatellc.com

Brian Schwan
772.286.5744 Office
772.215.1167 Mobile
bschwan@commercialrealestatellc.com

SITE PHOTOS



**JEREMIAH BARON
& CO**

COMMERCIAL REAL ESTATE

2100 SE Ocean Blvd. Suite 100
Stuart FL, 34996
www.commercialrealestatellc.com

Brian Schwan
772.286.5744 Office
772.215.1167 Mobile
bschwan@commercialrealestatellc.com

SITE PHOTOS



**JEREMIAH BARON
& CO**

COMMERCIAL REAL ESTATE

2100 SE Ocean Blvd. Suite 100
Stuart FL, 34996
www.commercialrealestatellc.com

Brian Schwan
772.286.5744 Office
772.215.1167 Mobile
bschwan@commercialrealestatellc.com

DEMOGRAPHICS

2023 Population Estimate		2023 Average Household Income		Average Age	
1 Mile	3,841	1 Mile	\$83,079	1 Mile	58.7
3 Mile	57,823	3 Mile	\$61,608	3 Mile	44.7
5 Mile	134,292	5 Mile	\$67,963	5 Mile	46.2

2028 Population Projection		2023 Median Household Income		Median Age	
1 Mile	4,121	1 Mile	\$64,243	1 Mile	52.3
3 Mile	61,153	3 Mile	\$43,857	3 Mile	43.9
5 Mile	141,264	5 Mile	\$49,901	5 Mile	44.7

**JEREMIAH BARON
& CO**

COMMERCIAL REAL ESTATE

2100 SE Ocean Blvd. Suite 100
Stuart FL, 34996
www.commercialrealestatellc.com

Brian Schwan
772.286.5744 Office
772.215.1167 Mobile
bschwan@commercialrealestatellc.com

ZONING INFORMATION

ZONING DISTRICT	R4A
-Detached House	P
-Duplex	P
-Townhouse	P
-Multi-Dwelling Building	P
-Mobile or Manufactured Home	-
-Manufactured Home Park or Subdivision	-
-Mobile Home Park	-
-Mixed-Use Building or Development	C
Home Occupations (per requirements of Section 125-318)	P
Group Living (except as noted below)	C
-Community Residential Home, Type 1 (1-6 residents)	P
-Community Residential Home, Type 2 (7-14 residents)	-
-Dormitories, Fraternity and Sorority Houses	C
Community/Cultural (except as noted below)	C
-Community Center	C
-Fraternal Organization/Lodge	C
-Library or Cultural Exhibit	C
-Environmental Research and Education Facilities	C

Day Care	C
-Adult Day Care Center	C
-Day Care Center	C
-Child Care Facility	C
-Family Day Care Home	P
Educational Facilities	
-College or University	C
-Elementary, Middle or High School	C
-Marine Research/Education Facilities	-

**JEREMIAH BARON
& CO**

COMMERCIAL REAL ESTATE

2100 SE Ocean Blvd. Suite 100
Stuart FL, 34996
www.commercialrealestatellc.com

Brian Schwan
772.286.5744 Office
772.215.1167 Mobile
bschwan@commercialrealestatellc.com

FLOOR SKETCH

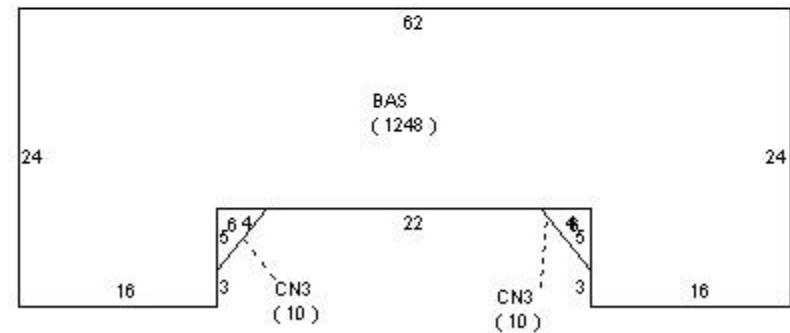
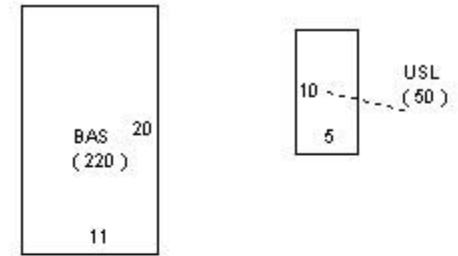
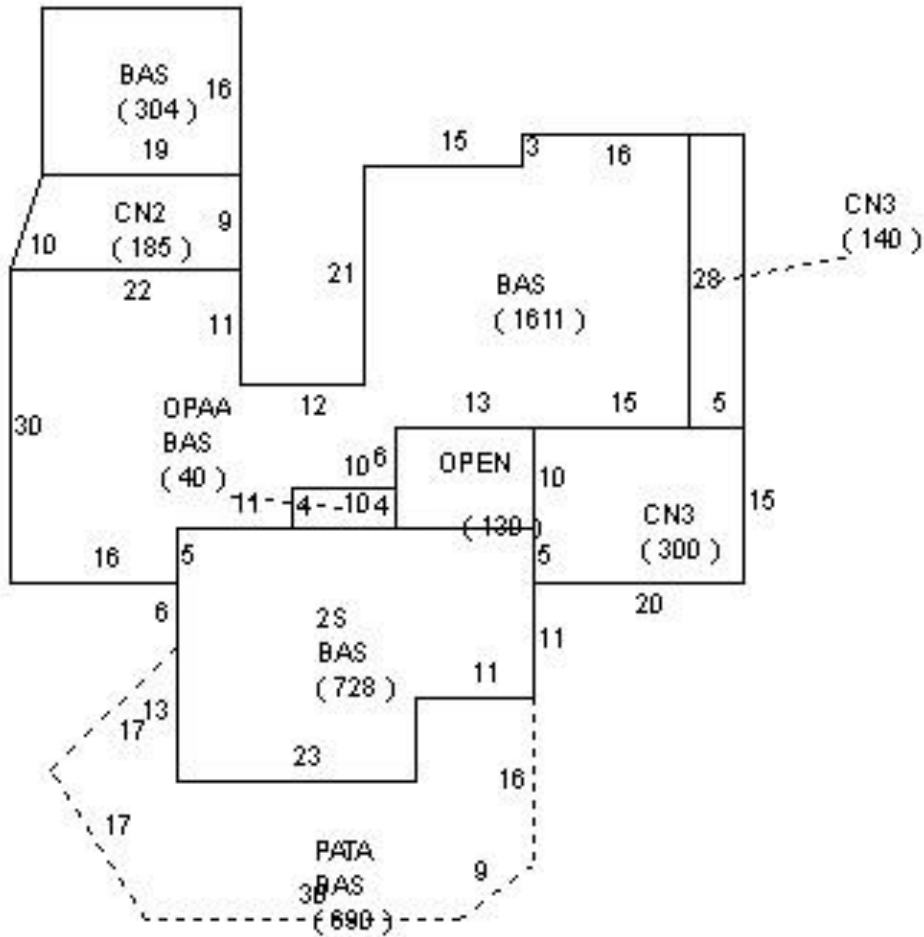

**JEREMIAH BARON
& CO**

COMMERCIAL REAL ESTATE

2100 SE Ocean Blvd. Suite 100
Stuart FL, 34996
www.commercialrealestatellc.com

Brian Schwan
772.286.5744 Office
772.215.1167 Mobile
bschwan@commercialrealestatellc.com

TRADE AREA MAP



**JEREMIAH BARON
& CO**

COMMERCIAL REAL ESTATE

2100 SE Ocean Blvd. Suite 100
Stuart FL, 34996
www.commercialrealestatellc.com

Brian Schwan
772.286.5744 Office
772.215.1167 Mobile
bschwan@commercialrealestatellc.com